



ZyNthAir

Gas mixer for PAC CID Cetane Analyzer
Providing a replacement for Synthetic Air

- ⊕ Mixes reliable and stable combustion air
- ⊕ Reduces the need for routine Cetane calibrations
- ⊕ Optimises the performance of PAC CID Cetane analysers

ACCURATE, EASY AND RELIABLE COMBUSTION AIR

The PAC ZyNthAir Gas Mixer is an accessory for existing CID Cetane Analyser that removes the need for synthetic air while producing constant, reliable and accurate combustion air. The ZyNthAir is backward compatible with existing CID users, and many of them will benefit from the reduced cost of purchasing synthetic air and the need to perform a Cetane calibration between gas cylinder swaps. The Gas Mixer requires three gas inputs: Nitrogen and Zero Air used to synthesise the 20% Oxygen for reliable combustion, and then small amounts of Oxygen for the automatic routine calibration of the Oxygen Sensor.

FEATURES AND BENEFITS

- Removes the need for Synthetic Air
- No more Cetane calibration on Cylinder changes
- Plug and play with existing CID systems, no requirement for a software update
- Oxygen content 20+/- 0.05% for high accurate Cetane measurement
- High-performance temperature controlled paramagnetic oxygen sensor with $\pm 0.01\%$ accuracy (intrinsic error)
- Auto-calibration of Oxygen Sensors
- Annual maintenance and calibration of pressure sensors with the last 6 records stored
- Self-diagnostics
- LCD interface shows current status, oxygen level and errors
- Visual LED for indication of status of the Gas Mixer
- Control App allowing for easy set-up maintenance and system review



TECHNICAL SPECIFICATIONS

Physical Specifications	
Size	Width 203 mm (8.0 in) Depth 508 mm (20.0 in) Width 610 mm (24.0 in)
Weight	34Kg
Power Requirements	
Input power voltage	90 to 240 VAC, Indoor use only
Frequency	50 to 60 Hz
Power Consumption	< 60 W
Gas Requirements	
Air Supply	Compressed clean dry air (Zero-Air recommended) Oxygen concentration: 20 - 22 % CO ₂ : < 1 ppm CO: < 1 ppm THC: < 0.1 ppm Water: < 2 ppm Pressure: 37 – 40 barg
Nitrogen Supply	Compressed Nitrogen Purity: ≥ 99.999% Pressure: 37 – 40 barg
Oxygen Supply	Compressed Oxygen Purity: ≥ 99.994% Pressure: 2.2 – 3.4 barg
Output Gas	
Combustion Air	Compressed combustion air Oxygen concentration: 20.0% ± 0.05%, Pressure: ≤ 25 barg
Environmental Conditions & Certification	
Operating Temperature	10 to 35°C (50 to 95°F), recommended 15 to 25°C (59 to 77°F)
Operating Humidity	≤ 85 % - non-condensing
Storage Temperature	-20 to 50°C (-4 to 122°F)
Storage Humidity	≤ 85 % - non-condensing
Pollution	Pollution Degree 2
Installation	Installation Category II
Altitude	≤ 2000 m
Ingress Protection	IP 54/NEMA 3
Certification	ISO 9001:2015, CE, ROHS II
Data Management	
Logging	Calibration data for Oxygen and Pressure Sensors Error tables-recording of error logs
Certifications	ISO 9001:2015, CE, ROHS II
Interface Specifications	
Display	LCD (2x16) Display shows status, %O ₂ , and alarm codes. Self-diagnosis tools
Web Client	Full Rich User Interface over a Control App provides information and control of: current system status, alarms, calibration, configuration and logging
Data input/output	1 Ethernet port: for laptop or external interface
Safety and Error Prevention	
Password security	Multi-level password protection, customer configurable

ZYNTHAIR WEBAPI

By connecting the ZyNthAir via Ethernet, users gain access to a powerful Control App that delivers a host of comprehensive maintenance features, precise system set-up, advanced control, and real-time status monitoring. The Control App enables fine-tuning and detailed adjustments on the ZyNthAir gas mixer, empowering users with unparalleled precision and flexibility for their gas mixing needs.

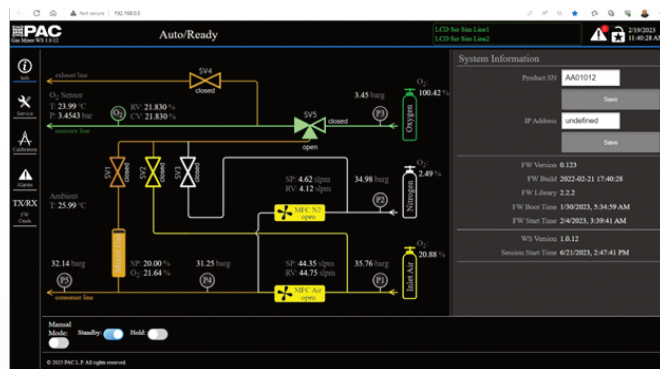

OXYGEN CONTENT

The ZyNthAir gas mixer stands as a pinnacle of precision, boasting the remarkable ability to produce unparalleled accuracy in oxygen content given your Cetane CID510 analyser reliable combustion gas to power better Cetane measurement.

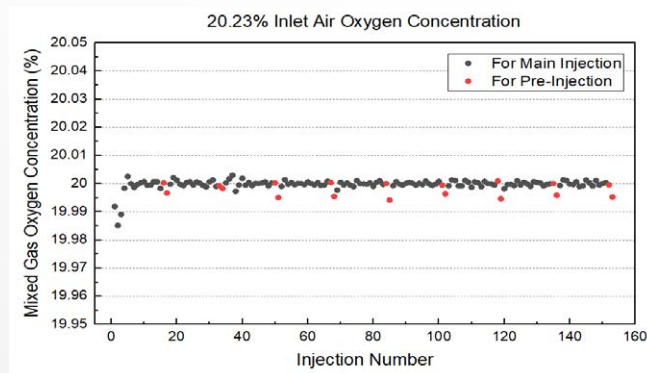

ABOUT PAC

PAC is a leading global solution provider of advanced analytical instruments for laboratories and online process applications. Our solutions are from industry-leading brands: AC Analytical Controls, Advanced Sensors, Alcor, Antek, Cambridge Viscosity, Herzog, Icon Scientific, ISL, Phase Technology, and Uson.

HEADQUARTERS

PAC LP | 8824 Fallbrook Drive | Houston, Texas 77064 | USA
T: +1 800.444.8378 | F: +1 281.580.0719

We are committed to delivering quality and superior local customer service worldwide. With 15 office locations and a network of over 50 distributors, PAC operates as a unit of Indicor, LLC, a diversified technology company that is a constituent of the S&P 500, Fortune 1000, and Russell 1000 indices.



Contact us for more details. Visit our website to find the PAC representative closest to you.

